

# *GM 47/GM 48*

## *Design Guidelines*

# CE

The product described in this manual conforms to the TTE directive 91/263/EEC and EMC directive 89/336/EEC. The product fulfils the requirements according to ETS 300 342-1.

The information contained in this document is the proprietary information of **Sony Ericsson Mobile Communications**. The contents are confidential and any disclosure to persons other than the officers, employees, agents or subcontractors of the owner or licensee of this document, without the prior written consent of **Sony Ericsson Mobile Communications**, is strictly prohibited.

Further, no portion of this publication may be reproduced, stored in a retrieval system, or transmitted in any form or by any means, electronic or mechanical, including photocopying and recording, without the prior written consent of **Sony Ericsson Mobile Communications**, the copyright holder.

## Second edition (June 2002)

**Sony Ericsson Mobile Communications** publishes this manual without making any warranty as to the content contained herein. Further **Sony Ericsson Mobile Communications** reserves the right to make modifications, additions and deletions to this manual due to typographical errors, inaccurate information, or improvements to programs and/or equipment at any time and without notice. Such changes will, nevertheless be incorporated into new editions of this manual.

All rights reserved.

© **Sony Ericsson Mobile Communications**., 2002

---

## Contents

<b>1</b>	<b>INTRODUCTION</b>	<b>5</b>
1.1	OVERVIEW	5
1.2	PRECAUTIONS	5
1.3	ABBREVIATIONS	5
<b>2</b>	<b>MECHANICAL INTEGRATION</b>	<b>7</b>
2.1	PHYSICAL DIMENSIONS	7
<b>3</b>	<b>ELECTRICAL INTEGRATION</b>	<b>8</b>
3.1	GENERAL	8
3.2	GROUNDING	9
3.2.1	<i>The Analogue Ground</i>	9
3.2.2	<i>The Digital Ground (DGND)</i>	9
3.3	EXTERNAL SUPPLY TO MODULE	10
3.3.1	<i>Power Supply (VCC)</i>	10
3.3.2	<i>General Recommendations</i>	11
3.3.3	<i>On/Off signal</i>	12
3.4	SIM CONNECTIONS	13
3.5	AUDIO CONNECTIONS	14
3.5.1	<i>Analogue Audio</i>	14
3.5.2	<i>Advanced Portable Hands Free Functionality</i>	15
3.6	RF AND ANTENNA INTEGRATION	16
3.7	INTERFACING TO A 3.3V $\mu$ PROCESSOR	17
3.8	SOFTWARE DOWNLOAD AND LOGGING CIRCUITRY	18
<b>4</b>	<b>DEVELOPERS BOARD</b>	<b>19</b>
4.1	POWER CIRCUIT	19
4.2	SIM CIRCUIT	19
4.3	ON/OFF SWITCH	19
4.4	PROGRAMMING CIRCUITRY	19
4.5	EMC	20
4.6	DATA SIGNALS:	20
<b>5</b>	<b>PART NUMBERS</b>	<b>21</b>
5.1	SYSTEM CONNECTOR	21
5.2	RF CONNECTOR	21
5.3	SIM CARD HOLDER	21
5.4	SUPPLIERS	21
5.4.1	<i>Imperial connectors</i>	21
5.4.2	<i>IMS connectors</i>	22
<b>6</b>	<b>TYPE APPROVAL</b>	<b>23</b>
6.1	DOCUMENTATION REQUIRED	23
6.2	POWER SUPPLY	24
6.3	SIM TESTING	25
6.4	EMC/ESD & SAFETY	25
6.5	RF TESTING	25
6.5.1	<i>GM47</i>	25
6.5.2	<i>GM48</i>	26
6.6	SAR WARNING	26
6.7	OTHER TA ISSUES	26
6.7.1	<i>External Application software</i>	26
6.7.2	<i>GM47 software updates</i>	26

**APPENDIX I - TECHNICAL DATA .....27**  
**APPENDIX II – GM47/48 PIN OUT .....29**  
**APPENDIX III GSM TRANSMIT WAVEFORM CHARACTERISTICS .....32**

# 1 Introduction

## 1.1 Overview

The GM47/48 belong to a new generation of Sony Ericsson Mobile Communications GSM modules. This document describes the main characteristics and functionality of the GM 47/48, two dual band products for 900/1800 MHz and 850/1900 MHz GSM bands respectively.

This document should be used in conjunction with either the GM 47/48 Integrators Manual or GM47/48 Technical Description and is intended to aid the system integrator both designing the module into their application and gaining the correct approvals.

## 1.2 Precautions

The GM47/48 are static sensitive devices (SSD's). Normal SSD procedures for electronic devices should be used when handling the modules. In the Integrators' Manual you will find more information about safety and product care. Never exceed these limits to ensure the module is not damaged.

## 1.3 Abbreviations

Abbreviation	Explanation
BT	Bluetooth
CBS	Cell Broadcast Service
CBM	Cell Broadcast Messaging
CSD	Circuit Switch Data
DCE	Data Circuit Terminating Equipment
DTE	Data Terminal Equipment
DTMF	Dual Tone Multi Frequency
EFR	Enhanced Full Rate codec
EMC	Electro-Magnetic Compatibility
ETSI	European Telecommunications Standards Institute
FR	Full Rate codec
GPRS	General Packet Radio Service
GPS	Global Positioning System
GSM	Global System for Mobile Communication
HR	Half Rate codec
HSCSD	High Speed Circuit Switched Data
ITU-T	International Telecommunication Union – Telecommunications Standardisation Sector
ME	Mobile Equipment

MO	Mobile Originated
MS	Mobile Station
MT	Mobile Terminated
PCM	Pulse Code Modulation
PDU	Protocol Data Unit
RLP	Radio Link Protocol
RF	Radio Frequency
RTC	Real Time Clock
SDP	Service Discovery Protocol
SMS	Short Message Service
SIM	Subscriber Identity Module
TBD	To Be Defined

---

## 2 Mechanical Integration

The GM 47/48 is protected with AISI 304 Stainless Steel covers suitable to fulfil the environmental and EMC requirements.

The position of the different connectors and mounting holes are shown in figure 2.1 with dimensions.

### 2.1 Physical Dimensions

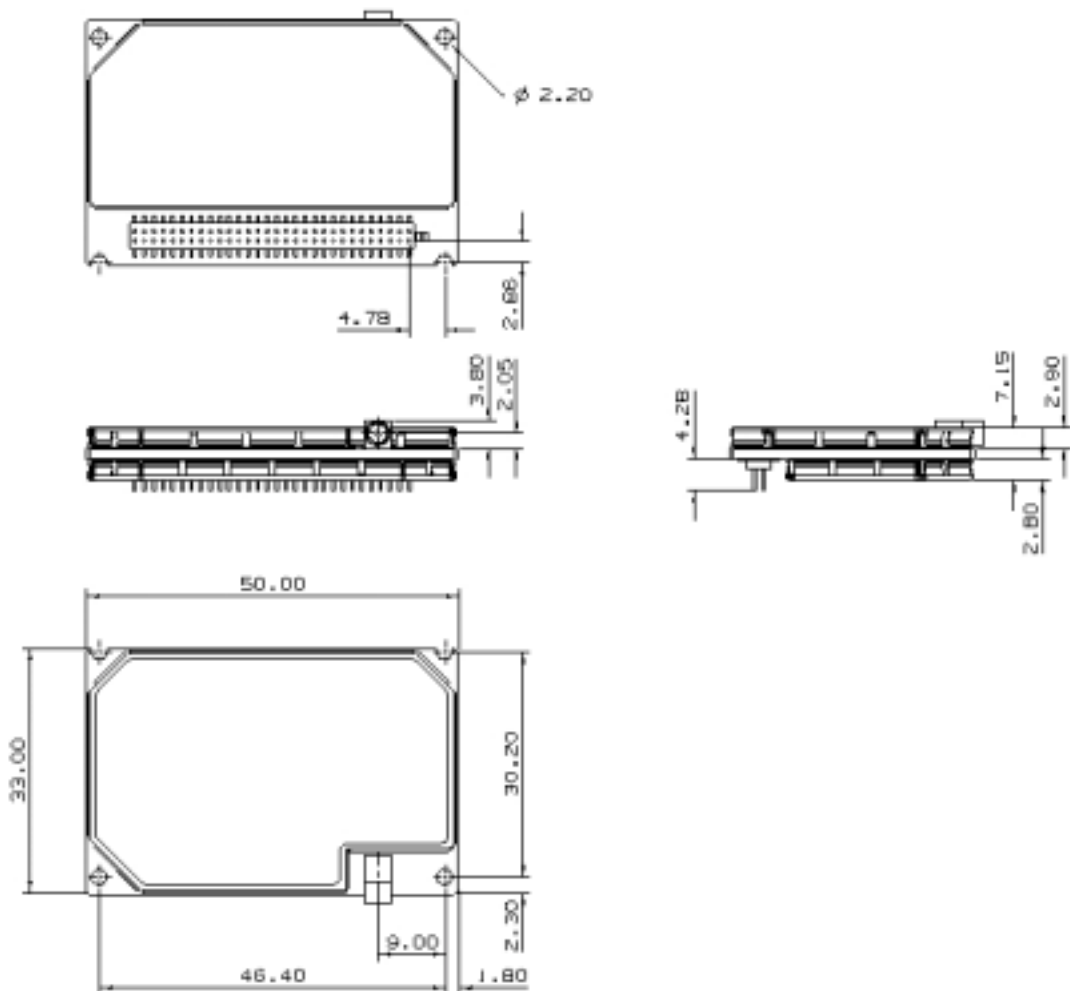

Figure 2.1 Physical dimensions of GM 47/48

### 3 Electrical Integration

#### 3.1 General

The electrical connections to the module (except the antenna), are set through the System Connector Interface.

The connector allows the following connections:

- board to board.
- board to cable.

See section 5 for suppliers and part numbers.

The figure 3.1 below indicates the pin numbering scheme.

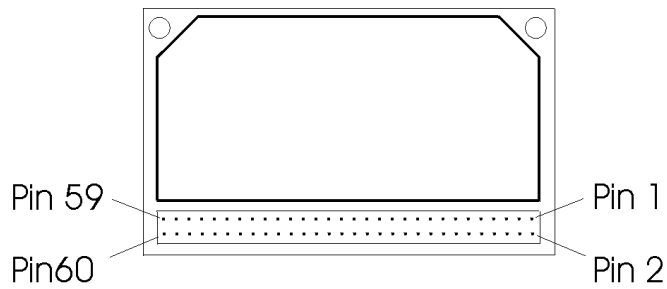

*Figure 3.1 GM 47/48. View from the underside*

## 3.2 Grounding

Pins	Name	Description
2, 4, 6, 8, 10, 12	DGND	Digital Ground
60	AGND	Analogue Ground

There are two ground signals in GM 47/48, Analogue Ground (AGND) and Digital Ground (DGND). The analogue Ground is connected to pin number 60, and the Digital Ground is connected to the System Connector Interface through pin numbers 2, 4, 6, 8, 10 and 12.

Note: All the Ground pins have to be connected to the application. The AGND is connected to the DGND in the ME, and only there. It is important that the AGND and the DGND are separated in the application.

### 3.2.1 The Analogue Ground

The AGND lead is the analogue audio reference ground. It is the return signal for Audio To Mobile Station (ATMS) and Audio From Mobile Station (AFMS).

It is connected to the Digital Ground (DGND) inside the module and only there. The application shall not connect DGND and AGND.

Parameter	Limit
$I_{\max}$	$\cong 12.5\text{mA}$

### 3.2.2 The Digital Ground (DGND)

DGND is the reference for all digital signals in the System Interface.

It shall also be the DC return for the power supply on VCC and SERVICE. Each DGND pin is rated at 0.5 A. All DGND pins are connected internally in the module.

Parameter	Limit
$I_{\text{average}}$	< 0.5 A No DGND pin can withstand over 0.5 A
$I_{\max}$	< 600 mA (100 mA each)

### 3.3 External Supply to Module

Pins	Name	Description
1, 3, 5, 7, 9, 11	VCC	Regulated Power Supply

Connect all of the pins together in the application in order to carry the current drawn by the module.

#### 3.3.1 Power Supply (VCC)

The VCC supplies the module with external power. Any other voltage needed is generated internally.

Parameter	Mode	Limit
Voltage to be applied	Nominal	3.6 Volts
	Tolerance	3.4 Volts - 4.0 Volts
	Maximum voltage drop during transmit burst	200mV
Over voltages		5.5 Volts
	Current Drive capability at TX Full Power	< 600 mA (average)) < 2 A (Peak)

GM 47/48 does not have internal capacitance to supply the large current peaks during GSM transmission. Therefore on burst transmission the application DC source is responsible for providing the appropriate current.

Recommendations to the design of power supplies are given in the following paragraphs.

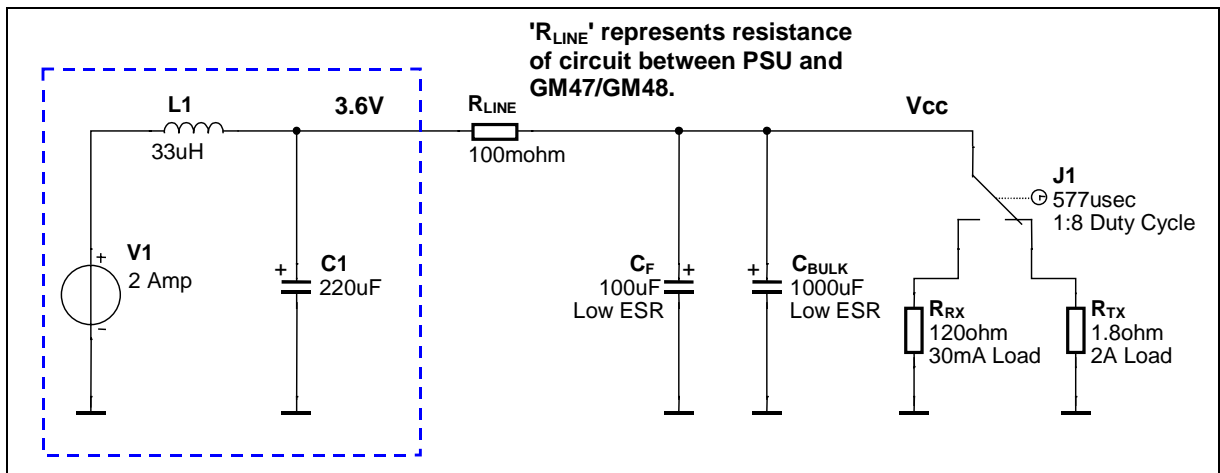

Figure 3.2 - Simplified Power Supply Reference Model

### 3.3.2 General Recommendations

The power supply conditions for the GM47/48 Vcc connection are as follows:

Maximum voltage drop during transmit burst	200mV
Maximum Ripple	TBD : [estimate 50mV]

Table 3.1

Recommended ESR on CBULK : <100mΩ

Recommended Maximum DC resistance between PSU and GM47 Vcc : <200mΩ

Recommended minimum CBULK : 1000μF [see tables below]

The following tables provide a quick indication to recommended CBULK capacitance to maintain Vcc drop <200mV for different PSU current delivery and DC resistance between PSU and Module Vcc.

CBULK ESR = 50mΩ		
R <sub>LINE</sub> = 50mΩ		
PSU LIMIT	CBULK (min)	Transmit Burst Vcc Dip (approx)
≥ 2.0 Amp	1000μF	120mV
1.5 Amp	*2500μF	170mV
1.0 Amp	*6000μF	160mV
0.5 Amp	*10000μF	165mV

Table 3.2

CBULK ESR = 50mΩ		
R <sub>LINE</sub> = 100mΩ		
PSU LIMIT	CBULK (min)	Transmit Burst Vcc Dip (approx)
≥ 2.0 Amp	1500μF	200mV
1.5 Amp	4000μF	150mV
1.0 Amp	*6000μF	170mV
0.5 Amp	*10000μF	180mV

Table 3.3

CBULK ESR = 50mΩ		
R <sub>LINE</sub> = 150mΩ		
PSU LIMIT	CBULK (min)	Transmit Burst Vcc Dip (approx)
≥ 2.0 Amp	4000μF	200mV
1.5 Amp	5000μF	190mV
1.0 Amp	*6000μF	190mV
0.5 Amp	*10000μF	200mV

Table 3.4

C <sub>BULK</sub> ESR = 50mΩ		
R <sub>LINE</sub> = 200mΩ		
PSU LIMIT	CBULK (min)	Transmit Burst Vcc Dip (approx)
≥ 2.0 Amp	6000μF	200mV
1.5 Amp	6000μF	190mV
1.0 Amp	6000μF	190mV
0.5 Amp	*12000μF	200mV

Table 3.5

Note: When this capacitance is used with the PSU conditions stated, the PSU will reach current limit. Although this condition on Vcc will not adversely affect the module performance, this may not be a condition appropriate to the supply and may adversely affect other devices sharing the PSU output. If the PSU cannot be driven to current limit, please select a non-current limiting configuration of CBULK and RLINE. It is the responsibility of the application developer to ensure correct operation of the PSU.

Further details of the GSM burst transmission waveform are given in appendix III.

### 3.3.3 On/Off signal

The on/off line should be attached to an open collector drive or momentary contact switch otherwise the module alarm clock feature will not operate. The on/off line is wired Red internally with the alarm wake up signal.

### 3.4 SIM connections

All track lengths between the SIM card and the module must be kept below 15cm. This is due to the voltage drop/capacitance associated with the extra track length and it has type approval issues as it will affect timing.

This is primarily designed as a 3 Volts SIM interface, but if a 5 Volts SIM card is connected to it the interface will automatically detect this and adjust the appropriate parameters.

SIM connections are shown below.

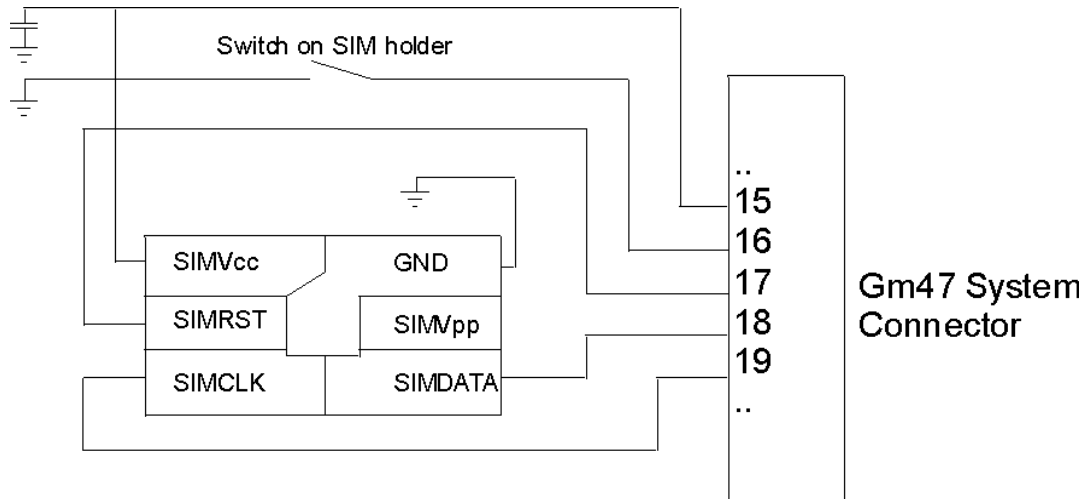

Figure 3.2 SIM Connections

Points to note regarding SIM connection

- The SIM does not need protection between it and the module, if protection is provided great care must be taken as SIM electrical testing for type approval is very sensitive to capacitance in the lines.
- De-coupling for Vcc is required, testing has been carried out using a 2.2uF ceramic capacitor.

### 3.5 Audio Connections

Audio connections for both of the analogue paths are shown below.

#### 3.5.1 Analogue Audio

<i>Pin</i>	<i>Signal</i>	<i>Dir.</i>	<i>Description</i>
57	AFMS	O	Audio From Mobile Station
59	ATMS	I	Audio To Mobile Station
60	AGND	-	Ground (return) for analogue audio

ATMS and AFMS are the audio input and output for the module. Figure 3.3 shows the connection of the analogue audio signals ATMS and AFMS to the CODEC. An Advanced Portable Hands Free accessory is also shown to clarify the connections.

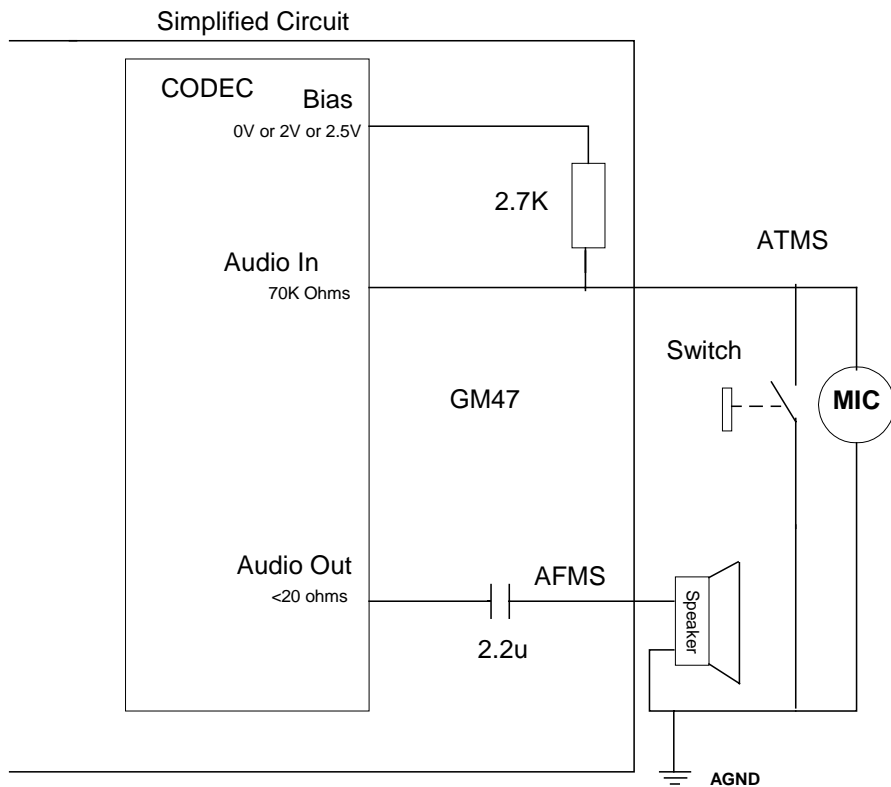

Figure 3.3. Analogue Audio Signal Connections.

It is possible to use the analogue audio signals in different modes.

- Hands-Free - This is the state referred to as Audio To Mobile Station ATMS and Audio From Mobile Station AFMS, which will be used by audio accessories like handsets or Hands Free equipment.

- **Portable Hands Free** - This state activates a different amplification factor in the GM47 and activates a microphone bias level of 2V in ATMS when a call is in progress. This is the default state at power-on.

### **Audio Circuit Electrical characteristics**

All sources must be AC-coupled except the Portable HandsFree microphone, which shall be DC-coupled in order to supply DC current to the Portable HandsFree microphone. AC coupling prevents incorrect biasing or damage of the ATMS input. The capacitor must have a value greater than shown below to avoid attenuation of low frequencies.

Application driving impedance (0.3 – 3.5 kHz)	$\leq 300 \Omega$	
AC coupling capacitance	$\geq 1 \mu\text{F}$	
Module input impedance (0.3 – 3.5 kHz)	$> 50 \text{ k}\Omega$	
Low frequency cut-off. (-3 dB)	300 Hz $\pm$ 50 Hz	
High frequency cut-off. (-3 dB)	$> 3500 \pm 50 \text{ Hz}$	
Output DC bias level	Hands-Free mode	0V
	Portable Hands Free Mode	$2.0\text{V} \pm 0.1\text{V}$
Additional Gain in Portable Hands Free Mode	28.5 dB	

Table 1. ATMS Levels. Audio Levels

### **3.5.2 Advanced Portable Hands Free Functionality**

This functionality consists in the detection of a push button press connecting **ATMS** to **AGND** for a certain period of time. This will create a change in the microphone DC bias level.

Microphone bias current at 2V <sup>1</sup>	$< 0.3 \text{ mA}$	
DC impedance for push button	Activated <sup>2</sup>	$< 100 \Omega$
	Deactivated <sup>3</sup>	$> 10 \text{ k}\Omega$ [TBC]

#### Portable Handsfree electrical data

AFMS is the analogue audio output from the module. When it is active, the output is derived from the PCM digital audio by the decoder part of the CODEC. The PCM data comes from PCMI on the system connector.

<sup>1</sup> Bias current  $> 0.7\text{mA}$  will cause false indication of button activation (Threshold is 100mV).

<sup>2</sup>  $2\text{V} \times (100 \Omega / (2700 \Omega + 100 \Omega)) = 71 \text{ mV}$ . Threshold is 100mV.

<sup>3</sup> Lower impedance will reduce bias on microphone.

It is also used as an ear-piece driver for the Portable Hands Free accessory.

Zout <sup>4</sup> (0.3 – 3.5 kHz)		≅ 120 Ω
Output capacitance		2.2 μF
Levels <sup>5</sup> (THD<5%)	Drive capability into 5 kΩ (0.3 – 3.5 kHz)	> 2.4 Vpp [TBC]
	Drive capability into 1.5 kΩ (0.3 – 3.5 kHz)	> 2.2 Vpp [TBC]
	Drive capability into 150 Ω (at 1 kHz)	> 1.3 Vpp [TBC]

Table 2. AFMS Levels. Audio Levels

### 3.6 RF and antenna Integration

The rules for RF and antenna integration are general good practice guidelines i.e.

- Ensure the antenna is a good 50Ω match across the GSM 900/1800 bands for GM47 and GSM 850/1900 bands for GM48.
- Antenna installation should be, where possible, not close to large metal objects as this will affect the matching mentioned above.
- A specifically designed antenna for the GSM signals being operated at will ensure the best reception.

If these are followed there should be no issues in terms of RF. For a more extensive guide please see the integrators manual.

Please also see section 6.6 regarding SAR.

<sup>4</sup> Output impedance includes impedance of EMC filter which is 100 Ω.

<sup>5</sup> Need to check output drive levels with 100R EMI filter.

### 3.7 Interfacing to a 3.3V $\mu$ Processor

CMOS gates are used within the GM47 and therefore the output drive is virtually rail to rail for small loads. So direct interface from the GM47 to low voltage logic gates is possible.

Expect  $V_{OHmin} = 2.5V$  for small loads (100 $\mu$ A).

Level shifting is required when driving into the GM47. This can be achieved using a simple resistive divider or a diode/resistor combination (see figure 3.4).

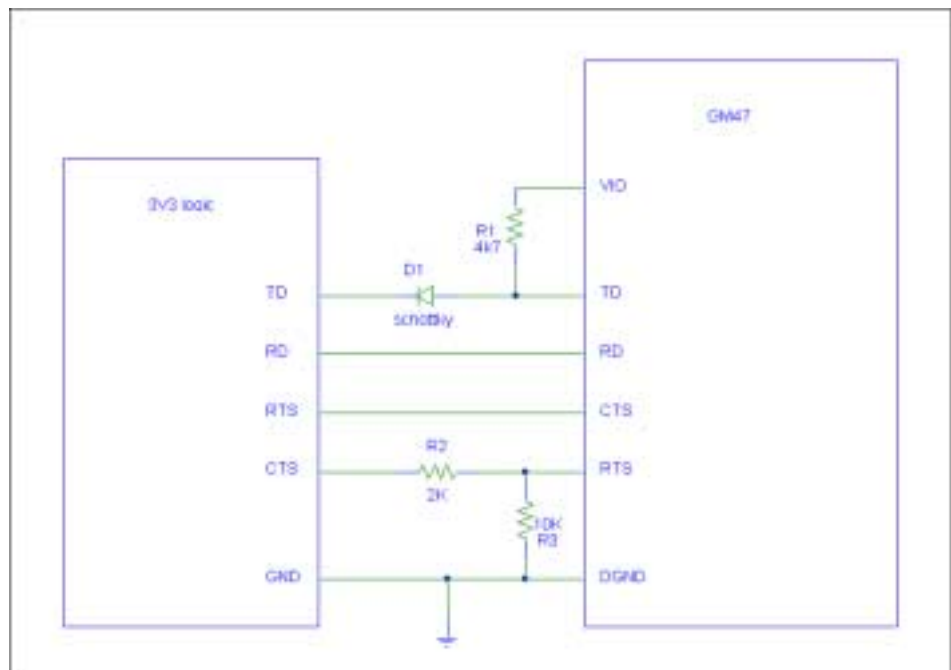

Figure 3.4 : Example of level shifting techniques

The diode based level shifter is the preferred option as it ensures the GM47 module cannot experience over voltage conditions whilst turned on and cannot be driven when the module is turned off, but the external circuitry remains powered. This circuit introduces some skew to the signal therefore care must be taken choosing the resistor value to match the data rate.

The resistive level shifter will subject the GM47 to 0.3V over voltage for worst case supply of 3.6V (3V3+10%), which is acceptable. When the module is turned off, but the external circuitry remains powered, current will be driven into the module. This situation should be avoided. The circuit introduces uniform skew to the signal, however it does add to the standby current for signals which are normally high.

Many level shifting I/C's are also available which would perform a similar function as described above i.e. a suitable device is a Max3372 for level shifting.

Note : ESD protection is not a requirement for the level shifter.

### 3.8 Software download and logging circuitry

Below the circuitry is shown which allows software download and logging to be performed.

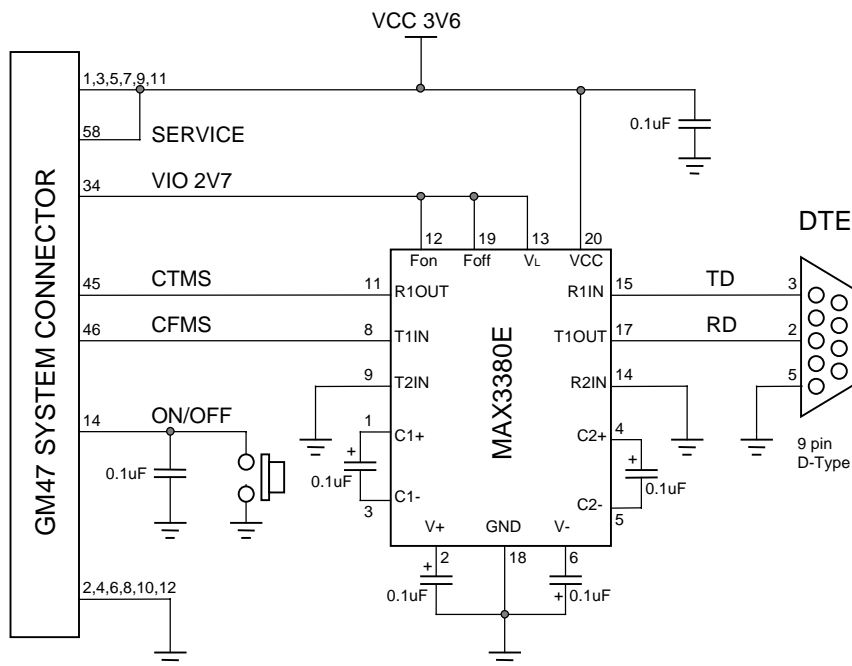

Figure 3.5 Service Circuitry

The data sheet for the Maxim device can be found at

<http://pdfserv.maxim-ic.com/arpdf/MAX3380E-MAX3381E.pdf>

## 4 Developers Board

The developers board is the reference design against which the module has been type approved, the circuit diagram for this is available upon request from customer support

### 4.1 Power Circuit

A 3A simple switcher step down voltage regulator has been used to produce the module Vcc. Two 6800 $\mu$ F capacitors are located adjacent to the module to cope with the GSM current pulses. The capacitors are low ESR type approximately 16m $\Omega$ .

### 4.2 SIM Circuit

The SIM holder has been connected directly to the module, the SIMVCC decoupling capacitor has been omitted and should be present for all designs.

Note: Provision was made for additional ESD protection on the board for development purposes.

This is not required and the devices have been removed from the SIMDATA and SIMCLK signals to minimize capacitance on these lines.

### 4.3 On/Off switch

The on/off line is connected to a momentary contact switch, this ensures correct operation of the alarm clock feature in the module.

### 4.4 Programming circuitry

The data lines are converted between 2.7V & 5V logic and then between 5V & RS232 levels. The data signal into the module is powered from the VIO supply interface which ensures isolation of the signal when the module is off.

To invoke programming mode the jumper JP27 is used. The Vppflash signal path is no longer used.

#### **4.5 EMC**

The circuit ground is bonded to the metal chassis of the developers kit box, all signal connections are filtered via ferrite chokes.

#### **4.6 Data signals:**

The data and handshake lines are converted between 2.7V & 5V logic and then between 5V & RS232 levels. The data signal and handshake lines into the module are powered from the VIO supply interface which ensures isolation of the signal when the module is off.

Diodes D3-5,D7 & D8 are not fitted.

## 5 Part numbers

### 5.1 *System connector*

A connector that can be used to interface to the system connector is the Samtech FLE or SFMC or CLP series, the female part number is CLP-130-02-F-D.

This connector or an equivalent can be sourced from imperial connectors below, again this company is just an example of one supplier.

### 5.2 *RF connector*

MMCX is a standard RF connector and should be able to be sourced from most suppliers.

### 5.3 *SIM card holder*

The data sheet for the SIM holder that is used on the developers board is available on request from customer support.

The card holder is a lockable type as problems have been experienced in the past with the slide in holders.

### 5.4 *Suppliers*

Below are listed suppliers of connectors which SonyEricsson uses, the quality or availability of components cannot be guaranteed.

#### 5.4.1 *Imperial connectors*

Imperial connectors have a good selection of SIM holders, the MMCX RF connector and the system connector.

##### **SIM card reader**

For the SIM card reader follow the link

<http://www.imperial-connect.co.uk/products/sim.html>

**System connector**

For the system connector follow

<http://www.imperial-connect.co.uk/products/prodprofile127.html>

click on ITRQPGA thumbnail.

**5.4.2 IMS connectors**

Connector cables from MMCX to SMA can be ordered from this supplier normally with a 2-3 week lead time.

## 6 Type Approval

The system integrator has to get CE marking for the integrated solution with the GSM module in Europe (GM47) and the FCC approval in the US (GM48). The system integrator only has to show compliance with the essential requirements of the module by the integration of it into the application.

If the external elements are designed according to the guidelines of this document the testing would be the following:

- Integration with GM47
  - EMC in all modes of operation
  - Safety
- Integration with the GM48
  - FCC approvals of all applicable parts

Sony Ericsson recommends that all these tests are performed by the customer in an accredited test house. After that, all documentation together with the test reports and certificates of the application should be sent to Sony Ericsson in order to register the application to the accessories list for the approval of the module, this will aid the approval of the application world wide.

Currently Sony Ericsson are working with a test house to provide a complete TA service for applications with the GM47, please contact customer support for more details.

### 6.1 *Documentation required*

The system integrator is required to produce a document which will be submitted to the test house containing the following information.

- Summary of the application
- Hardware description
- Block diagram with an explanation
- Schematics
- PCB/Component layout
- Bill of materials

This documentation will also be required for Sony Ericsson to add the application to the list of approved accessories for the module in addition to the test reports and certificates obtained from the test house.

## **6.2 Power supply**

It is essential the application power supply is designed to comply with the specification in section 3. This will be sufficient to pass type approval, no RF testing will be required if it meets these specifications.

### **6.3 SIM Testing**

SIM electrical testing does need to be carried out since the electrical paths from which it was originally approved against (developers kit board) have changed. This will typically take around 3 hours in a test house.

Other points to note regarding the implementation of the SIM card holder are as follows.

- SIM presence must be implemented to comply with the module approval conditions.
- Any manufacturers SIM card holder can be used and this can also be either 6 or 8 pins.

### **6.4 EMC/ESD & Safety**

EMC and safety tests according to the ITU/GSM and FCC standards will have to be completed as part of the mandatory testing. The GM 47/48 were originally type approved outside of a metal box. Additional shielding is not strictly required the external application. This is the responsibility of the system integrator. Overall ESD protection should be guaranteed by the system integrator.

The EMC standard which the application must be tested to is EN 301 489-7, this can be found at the following web site.

<http://www.etsi.org/getastandard/home.htm>

The safety standard which the application must be tested to is EN 60950, the can be found at the following web site

<http://www.iec.ch/>

For the GM48 FCC part 15 regulations, these can be found at

<http://www.fcc.gov/>

### **6.5 RF Testing**

#### **6.5.1 GM47**

As long as the antenna connected to the module is of the correct impedance as specified in section 3.7 and is passive further RF testing for TA is not required. Although it should be noted that radiation performance is the responsibility of the system integrator.

### **6.5.2 GM48**

According to the US rules (GM48) any change in RF path i.e. the antenna path will require new approval according to FCC part 22 and 24.

### **6.6 SAR warning**

If the application is using an antenna which is less than 20cm away from the any part of the users body, integrators are legally obliged to publish SAR figures for the product. This testing would need to be carried out by the system integrator.

The GM48 module is FCC approved for fixed and mobile applications. If the final product after integration is intended for portable use, a new application and FCC ID is required.

Even if SAR measurements are not required it is considered good practice to insert a warning in any manual produced indicating it is a radio product and that care should be taken.

### **6.7 Other TA issues**

#### **6.7.1 External Application software**

If the software of the external application is changed it has no effect upon the type approval certificate issued to it.

#### **6.7.2 GM47 software updates**

If the GM47 software is updated there should be no further action required by the system integrator as accessories lists are generally carried across between TA certificates and any software supplied by Sony Ericsson will be fully Type Approved.

## Appendix I - Technical Data

### *Mechanical specifications*

Maximum length:	50 mm
Maximum width:	33 mm
Maximum thickness:	6.82 mm (without system connector pins length)
Weight:	18,5 g

### *Power supply voltage, normal operation*

Voltage:	3.6V Nominal
Tolerance	±0.2V
Ripple:	<100mV @ 200KHz, <20mV @ >200KHz
Voltage must always stay within a normal operating range, ripple included.	
Power consumption:	Speech mode < 600 mA (< 2 A peak) Idle mode: 5 mA Switched off: < 100 µA

### *Radio specifications*

Frequency range:	GM 47: EGSM 900 MHz and 1800 MHz (Dual Band) GM 48: GSM 850 MHz and 1900 MHz (Dual Band)
Maximum RF output power:	2 W / 1 W
Antenna impedance:	50 Ω

### *SIM card*

SIM card interface:	3 V or 5 V
Support of external SIM card	

### *Environmental specifications*

Operating temperature range:	-25 0C to +55 0C
Storage temperature range:	-40 0C to +85 0C
Maximum relative humidity:	95% at +40 0C
Stationary vibration, sinusoidal:	Displacement: 7.5 mm Acceleration amplitude: 20 m/s <sup>2</sup> 40 m/s <sup>2</sup> Frequency range: 2-8 Hz 8-200 Hz 200-500 Hz
Stationary vibration, random	Acceleration spectral density (m <sup>2</sup> /s <sup>2</sup> ): 0.96 2.88 0.96 Frequency range: 5-10 10-200 200-500 60 min per/axis
Non-stationary vibration, including shock	Shock response spectrum I, peak acceleration: - 3 shocks in each axis and direction: 300 m/s <sup>2</sup> , 11 ms

## GM47/48 Design Guidelines

Shock response spectrum II, peak acceleration: - 3 shocks in each axis and direction: 1000 m/s<sup>2</sup>, 6 ms

Bump:	Acceleration 250 m/s <sup>2</sup>
Free fall transportation:	1.2 m
Rolling pitching transportation:	Angle: ±35 degrees, period: 8s
Static load:	10 kPa
Low air pressure/high air pressure:	70 kPa / 106 kPa

### Storage

SMS Storage capacity	40 in ME Upto 25 on SIM (SIM dependent)
Phone book capacity	100

### DAC

Parameter	Value	Units
Resolution	8	bit
Output voltage swing for Code=00 <sub>HEX</sub>	0.138 ± 0.1	V
Output voltage swing for Code=FF <sub>HEX</sub>	2.61 ± 0.2	V
Nominal Step Size	9.668 ± 0.1	mV
Linear Code Range	8-247 (8 <sub>H</sub> -F7 <sub>H</sub> )	LSB
Absolute Error during Linear Range	±100	mV
Conversion Speed	<100	µs

### ADC

Parameter	Value	Units
Resolution	8	bit
Input voltage for Code=00 <sub>H</sub>	0.01 ± 0.01	V
Input voltage for Code=FF <sub>H</sub>	2.75 ± 0.1	V
Nominal Step Size	10.742	mV
Accuracy	±3	LSB
Input Impedance	>1	MΩ
Conversion Time to within 0.5bit	<100	µs

## Appendix II – GM47/48 Pin out

<i>Pin</i>	<i>Signal Name</i>	<i>Dir</i>	<i>Signal Type</i>	<i>Description</i>
1.	VCC	-	Supply	Power Supply
2.	DGND	-	-	Digital Ground
3.	VCC	-	Supply	Power Supply
4.	DGND	-	-	Digital Ground
5.	VCC	-	Supply	Power Supply
6.	DGND	-	-	Digital Ground
7.	VCC	-	Supply	Power Supply
8.	DGND	-	-	Digital Ground
9.	VCC	-	Supply	Power Supply
10.	DGND	-	-	Digital Ground
11.	VCC	-	Supply	Power Supply
12.	DGND	-	-	Digital Ground
13.	Reserved for future use			
14.	ON/OFF	I	Internal pull up, open drain	Turns the module on/off Former WAKE_B
15.	SIMVCC	-	Dig. 3/5 V	SIM card power supply Power output for SIM Card from module
16.	SIMPRESENCE	I	Internal pull up, open drain	SIM Presence A "1" shall indicate that the SIM is missing; a "0" that it is inserted.
17.	SIMRST	O	Dig. 3/5 V	SIM card reset
18.	SIMDATA	I/O	Dig. 3/5 V	SIM card data
19.	SIMCLK	O	Dig. 3/5 V	SIM card clock
20.	DAC	O	Analogue	Digital to Analogue converter
21.	IO1	I/O	Digital, 2.75	General purpose input/output 1
22.	IO2	I/O	Digital, 2.75	General purpose input/output 2
23.	IO3	I/O	Digital, 2.75	General purpose input/output 3
24.	IO4	I/O	Digital, 2.75	General purpose input/output 4
25.	VRTC	I	Supply 1.5 V	Voltage for real time clock
26.	ADC1	I	Analogue	Analogue to Digital converter 1
27.	ADC2	I	Analogue	Analogue to Digital converter 2
28.	ADC3	I	Analogue	Analogue to Digital converter 3
29.	SDA	I/O	2.75, internal pullup	I <sup>2</sup> C Data
30.	SCL	O	2.75, internal pullup	I <sup>2</sup> C Clock
31.	BUZZER	O	Dig. 2.75	Buzzer output from module

32.	TIMESTAMP	O	Dig. 2.75	Timestamp Timestamp is reserved for future use, if A-GPS is implemented on network side.
33.	LED	O	Dig. 2.75	Flashing LED
34.	VIO	O	Power Out 2.75	Module powered indication. The VIO is a 2.75 V output that could power external devices to transmit data towards the GSM device to a 75mA max.
35.	TX_ON	O	Dig 2.75	This output shall indicate when the GSM module is going to transmit the burst.
36.	RI	O	Dig. 2.75	Ring Indicator
37.	DTR	I	Dig. 2.75	Data Terminal Ready
38.	DCD	O	Dig. 2.75	Data Carrier Detect
39.	RTS	I	Dig. 2.75	Request To Send
40.	CTS	O	Dig. 2.75	Clear To Send
41.	TD	I	Dig. 2.75	Transmitted Data Data from DTE (host) to DCE (module). [former DTMS]
42.	RD	O	Dig. 2.75	Received Data Data from DCE (module) to DTE (host). [former DFMS]
43.	TD3	I	Dig. 2.75	UART3 Transmission Data from DTE (host) to DCE (module). [former DTMS]
44.	RD3	O	Dig. 2.75	UART3 Reception Data from DTE (host) to DCE (module). [former DTMS] Data from DCE (module) to DTE (host). [former DFMS]
45.	TD2	I	Dig. 2.75	UART2 Reception Former CTMS. Used for flashing
46.	RD2	O	Dig. 2.75	UART2 Transmission Data from DCE (module) to DTE (host). [former DFMS] Former CFMS. Used for flashing
47.	PCMULD	I	Dig. 2.75	DSP PCM digital audio input
48.	PCMDLD	O	Dig. 2.75	DSP PCM digital audio output
49.	PCMO	O	Dig. 2.75	Codec PCM digital audio output
50.	PCMI	I	Dig. 2.75	Codec PCM digital audio input
51.	PCMSYNC	O	Dig. 2.75	DSP PCM frame sync
52.	PCMCLK	O	Dig. 2.75	DSP PCM clock output
53.	MICP	I	Analogue	Microphone input positive
54.	MICN	I	Analogue	Microphone input negative
55.	BEARP	O	Analogue	Speaker output positive

## GM47/48 Design Guidelines

---

56.	BEARN	O	Analogue	Speaker output negative
57.	AFMS	O	Analogue	Audio output from module
58.	SERVICE	I	12V/2.7V	Flash programming voltage for the MS. Enable logger information if no flashing Former VPPFLASH
59.	ATMS	I	Analogue	Audio input to module
60.	AGND	-	-	Analogue ground

---

## Appendix III GSM transmit waveform characteristics

The simplified GSM loading characteristics and power supply reference model in relation to the GM47 system connector is represented in figure 1. J1 represents the interface to the GM47 system connector and the voltage there is referenced Vcc.

Figure 2 shows a 1:8 cycle with the receive burst occurring in timeslot 1 and transmit in timeslot 6. Some of the quiet period is used by the module to 'listen' to other GSM base-stations.

In simple terms the module can draw up to 2 Amps during the transmit burst. The receive burst can draw up to 100mA. As the current consumption of the receive burst does not normally cause problems for power supply current drain, the simplified PSU model in figure 1 combines the receive, monitor and idle frames into an average current consumption around 30mA. The transmit burst requires special attention.

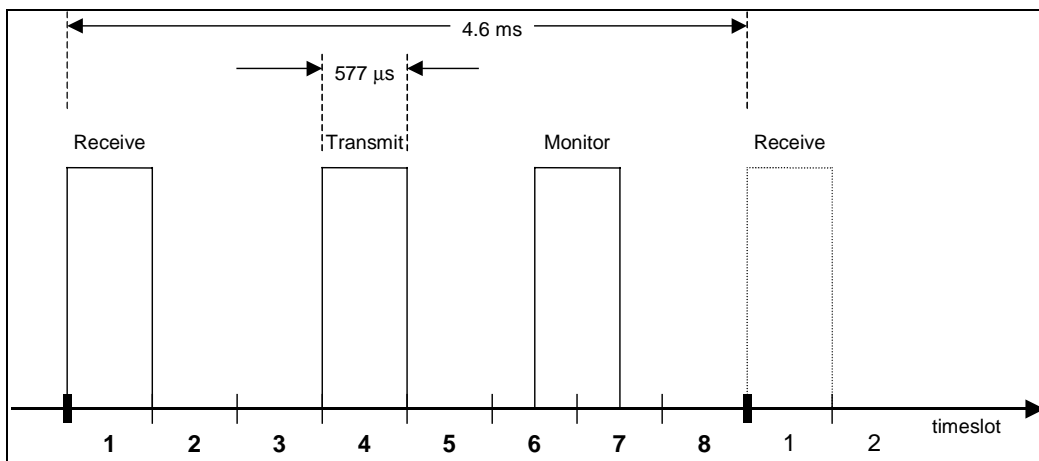

**Figure 1 - Simplified GSM Timing Diagram**

There are three main areas to consider in order to meet the transmit burst requirements: PSU current capability, resistance between the supply and module ( $R_{LINE}$ ), and bulk capacitance ( $C_{BULK}$ ) at the module Vcc connection. The effect that each of these parameters has on the waveform shape at Vcc is indicated in figure 3.

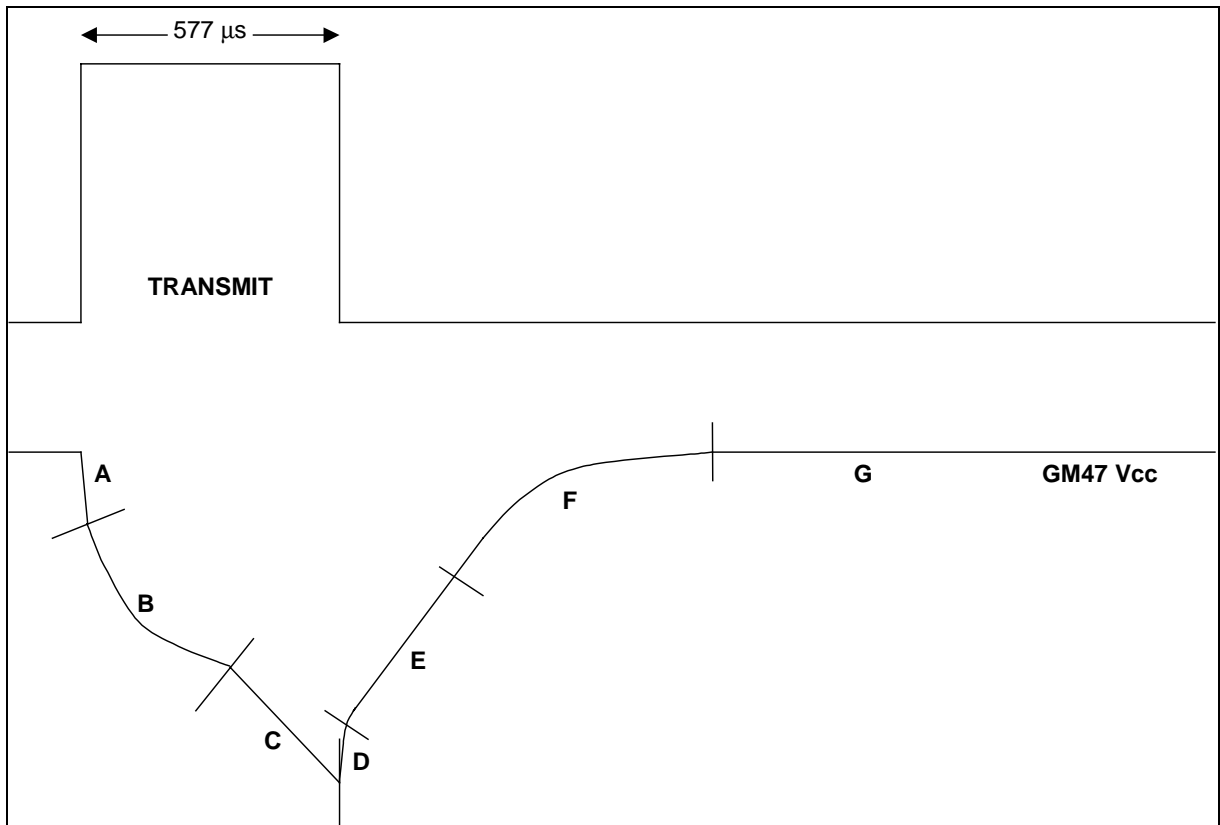

**Figure 2 - Transmit Burst Vcc Waveform**

- A. The sharp fall in voltage in this region is caused by the ESR of the capacitors (mounted as close to the module Vcc pins as possible).
- B. The RC discharge is controlled by CBULK, RLINE, and RTX.
- C. If the PSU cannot supply the 2A max load of the GM47 and current limit is reached the discharge of CBULK goes linear. If current limit is not reached then section 'B' will continue for the length of the transmit burst. Current limit will be reached when the voltage dropped across RLINE reaches  $V = I_{LIM} * R_{LINE}$ .
- D. The sharp fall in voltage in this region is again caused by the ESR of the capacitors.
- E. CBULK will charge linearly while the supply is in current limit. This section is not relevant while the PSU is not current limited.
- F. The RC charge is controlled by CBULK and RLINE.
- G. Once the transmit burst is finished, the 1:8 duty cycle should ensure that there is sufficient time for the PSU to fully recover before the next transmit burst.